

| LOC | DIST | REVISIONS | | | |
|-----|------|---------------------------------|-----------|-----|-------|
| F | LTR | DESCRIPTION | DATE | OWN | APPRO |
| G | | REV & REDWN PER EC 0G1B-00B7-99 | 04-JUN-99 | KW | J5 |

- 1. RECOMMENDED PANEL THICKNESS 2.29 MAX.
- 2. OPTIONAL CONSTRUCTION.
- 3. MARKING FOR UL LOGO AND CSA LOGO LOCATED APPROXIMATELY AS SHOWN.

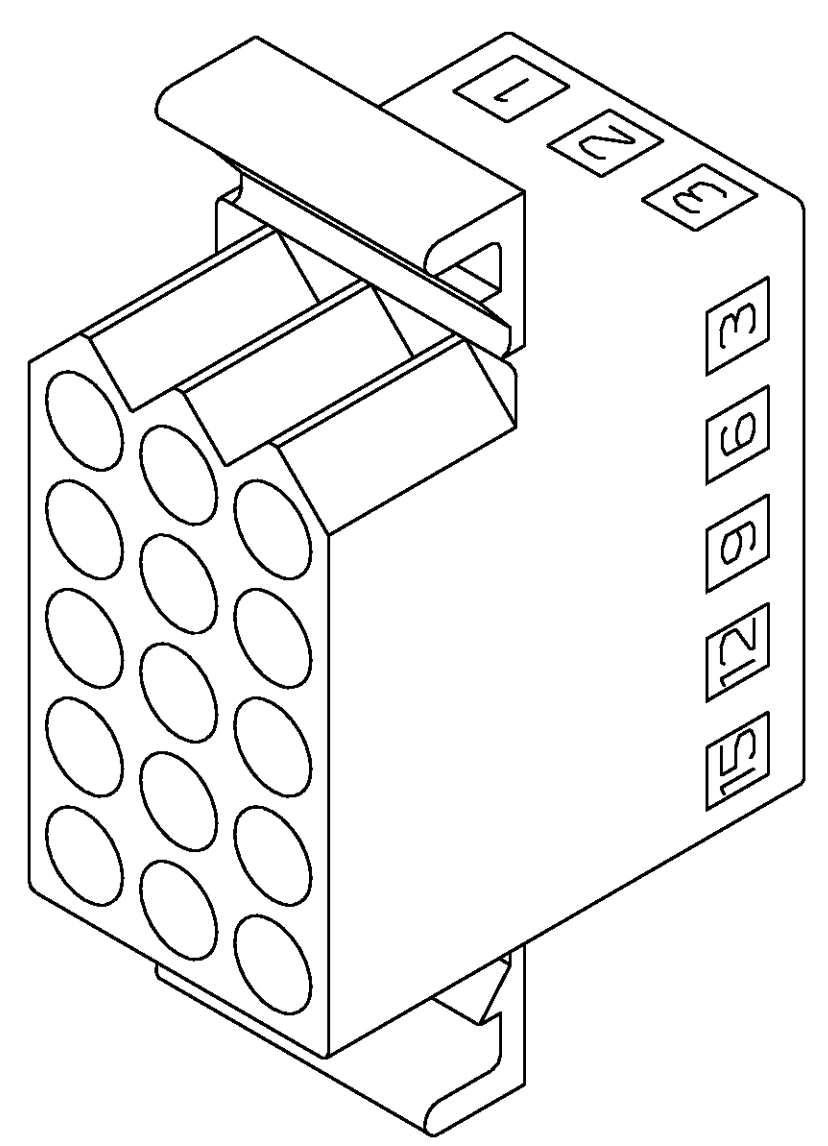

3-DIMENSIONAL MODEL
NTS

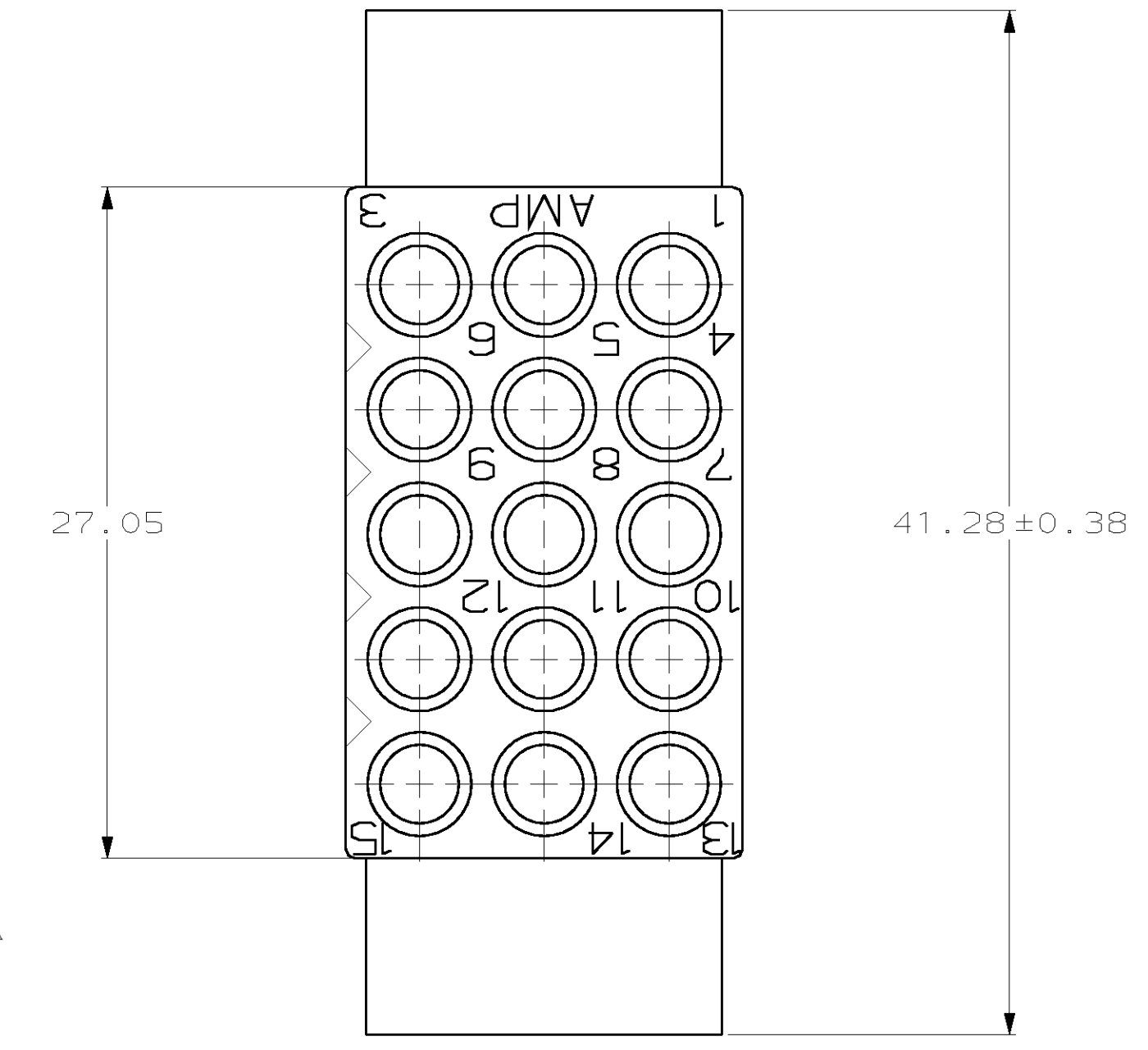
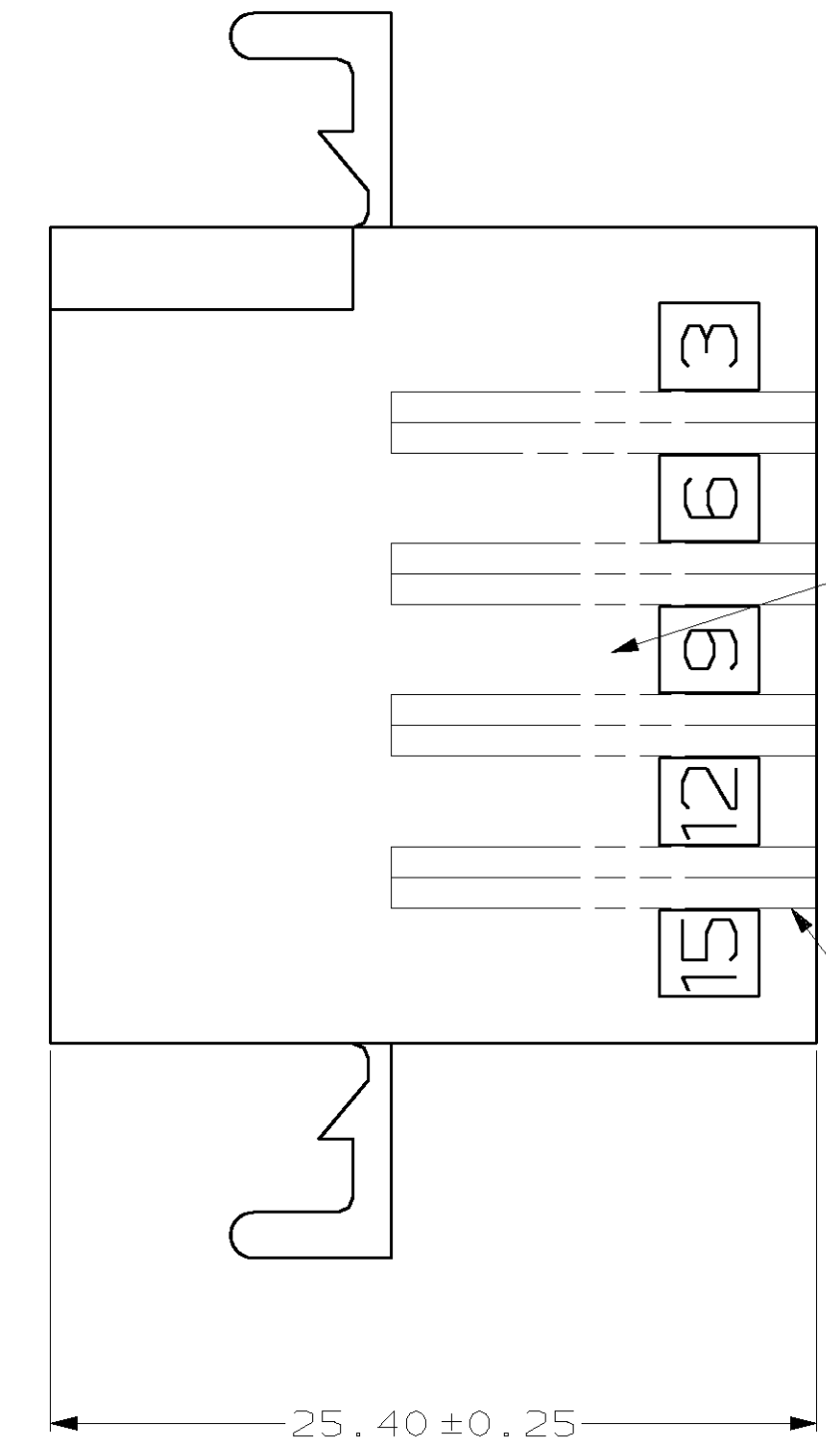
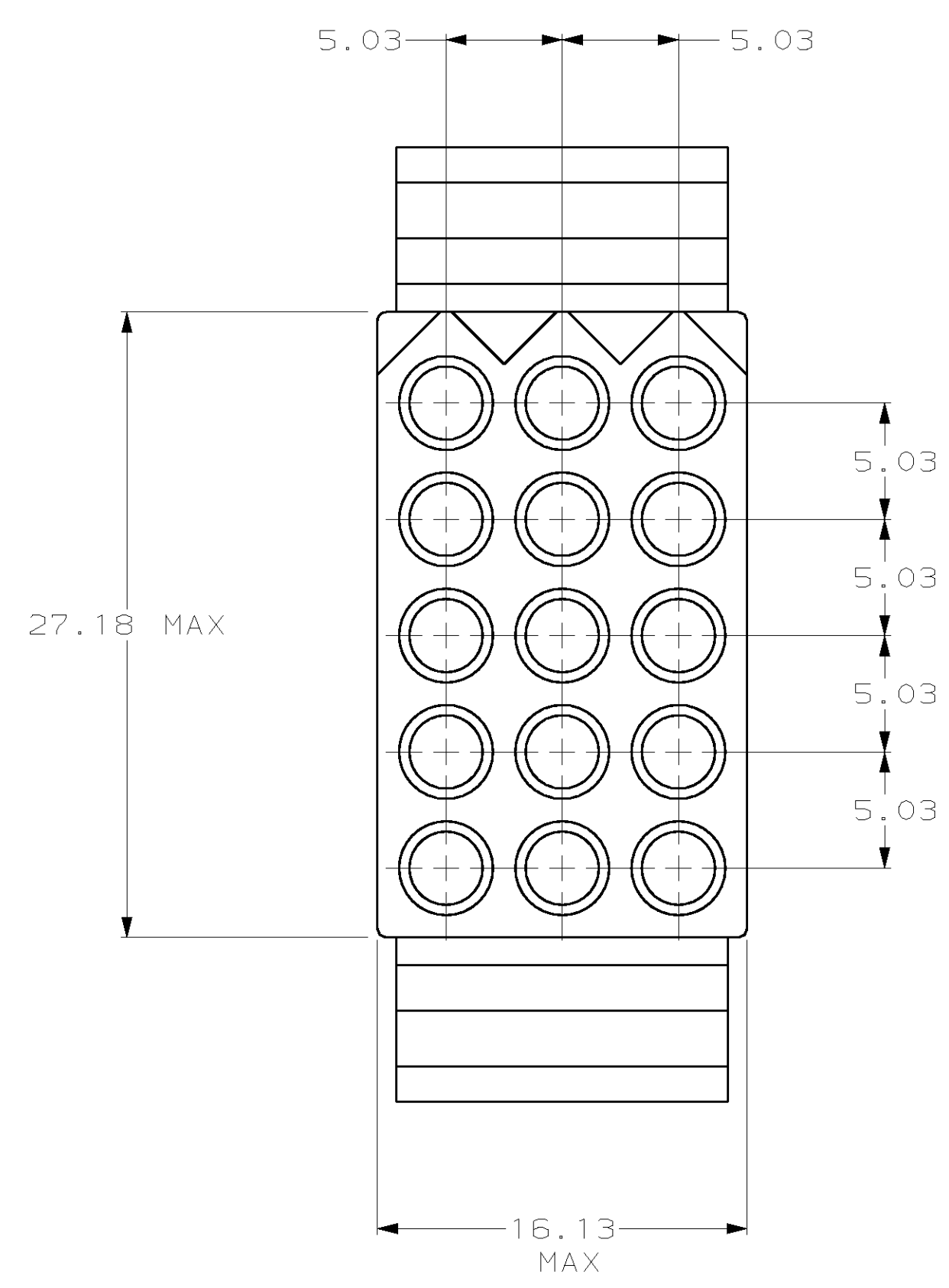
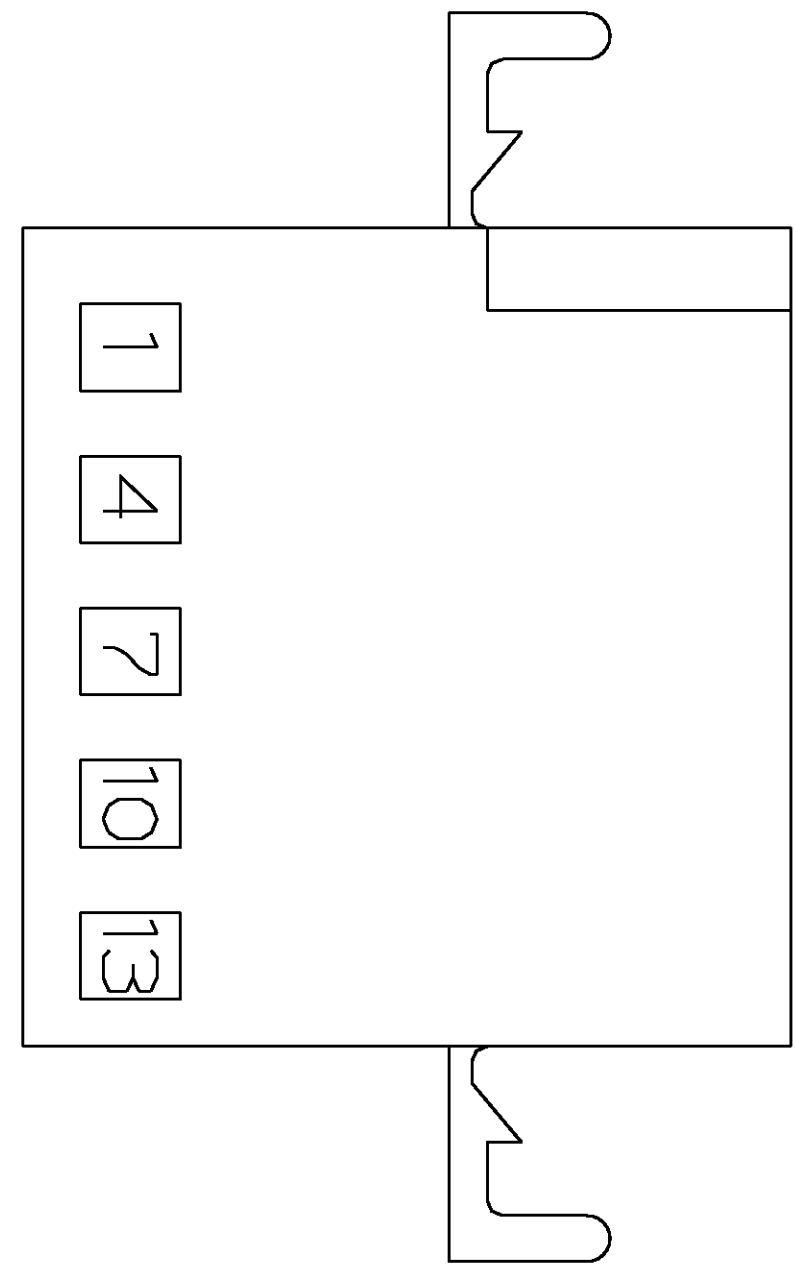
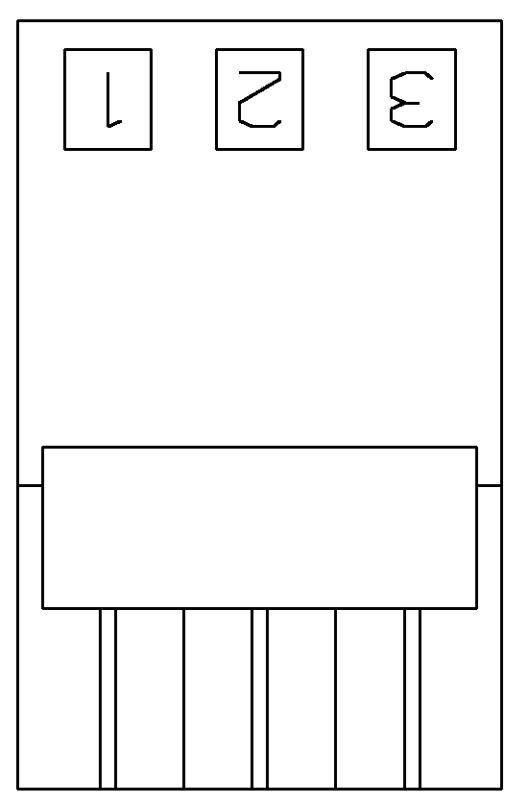
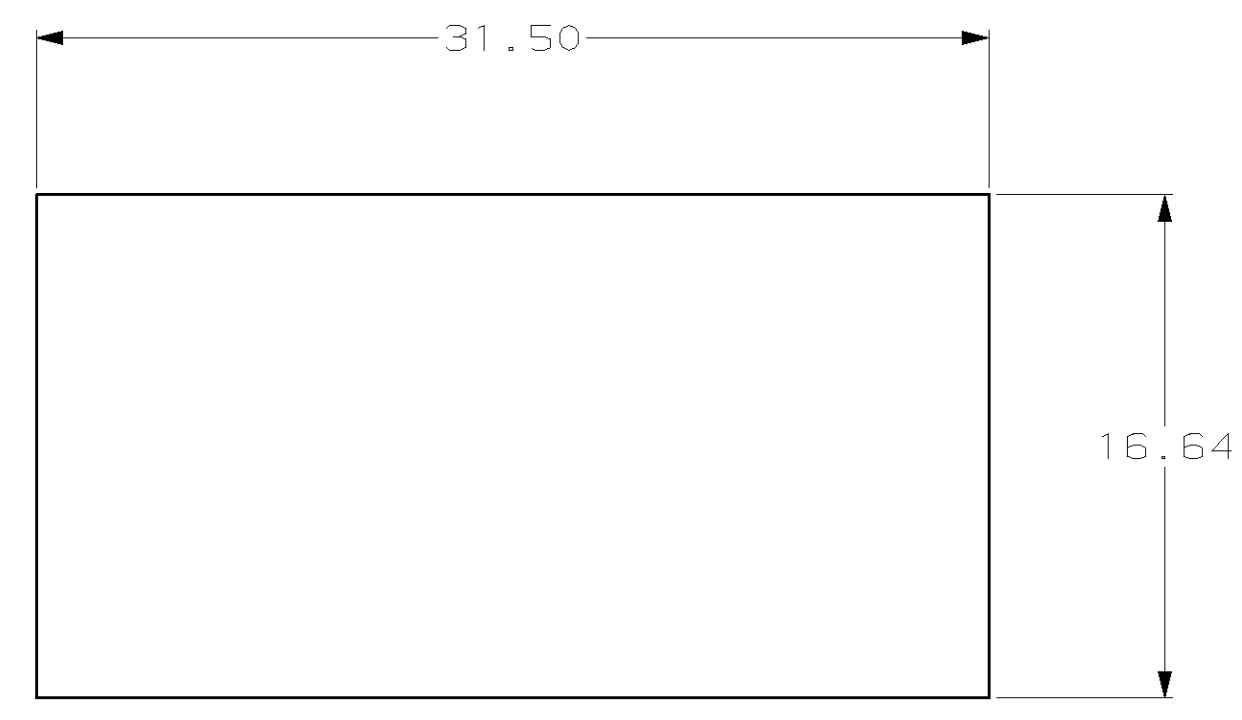
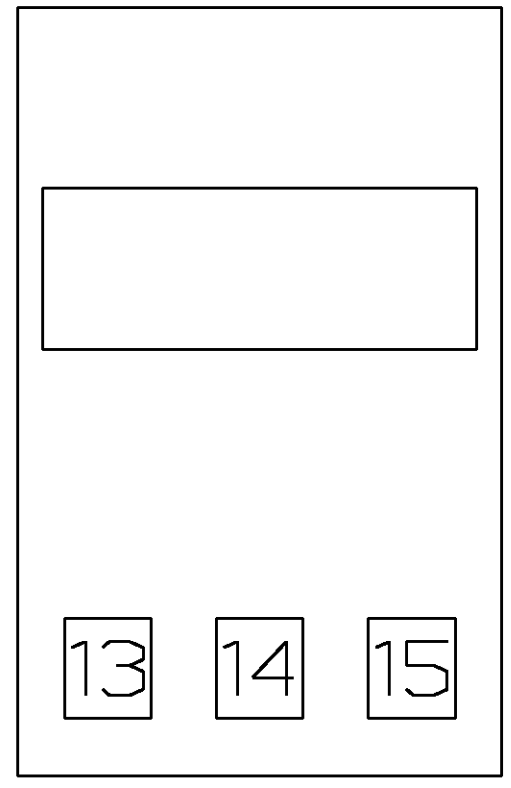

RECOMMENDED PANEL CUT OUT

| | | | |
|-------|------|-------|-------|
| 16.13 | .635 | - | - |
| 5.03 | .198 | 41.28 | 1.625 |
| 2.36 | .093 | 31.50 | 1.240 |
| 2.29 | .090 | 27.18 | 1.070 |
| 0.38 | .015 | 27.05 | 1.065 |
| 0.25 | .010 | 25.40 | 1.000 |
| 0.13 | .005 | 16.64 | .655 |
| MM | IN | MM | IN |

CONVERSION TABLE



THIS DRAWING IS A CONTROLLED DOCUMENT.

| | | |
|-------|-------------|-------------|
| DW | K. WHITAKER | 04-JUN-1999 |
| CHK | J. SCHLUNZ | 04-JUN-1999 |
| APPRO | J. SCHLUNZ | 04-JUN-1999 |

AMP AMP Incorporated
Harrisburg, PA 17105-3608

NAME: RECEPTACLE, 15 CIRCUIT,
.093 COMMERCIAL PIN AND SOCKET

SIZE: A1 00779 C- 770103

CUSTOMER DRAWING SCALE: 4:1 SHEET: 1 OF 1 REV: G

770103-1
PART NUMBER